



Humane Slaughter Association

Transport of Livestock

This is the downloadable version of the online guide. As such, some of the features may be missing, including video footage and web links. Visit the online version at www.hsa.org.uk

Introduction



Driving any vehicle brings with it a great deal of responsibility, and livestock drivers, in particular, require specialist knowledge and skills. Not only do they need to know about vehicle and road transport regulations, but also how to protect the welfare of animals in their care.

The purpose of this guide is to provide the key facts and figures which are essential for every livestock driver. This guide deals with the handling and transport of cattle, sheep and pigs. It does not cover the handling and transport of poultry, or the specialist air, rail and sea transport of livestock.

Please do not read further if you feel you may be negatively affected by the content.

Important Points About This Website

This guide is intended to assist operators involved in transporting livestock. Transporting livestock can be dangerous. You are advised to follow your employer's recommendations and procedures with particular care. If you are in any doubt as to any aspect of the safe transport of animals or the operation of handling systems, you should consult your manager or the manufacturer. In no circumstances can the Humane Slaughter Association (HSA) accept any liability for the way in which animals are transported, handled, or handling systems are used, or any loss, damage, injury or death caused thereby, since this depends on circumstances wholly outside the HSA's control.

The HSA aims to provide up-to-date and accurate information. If you have suggestions for improving any of the material included in this guide please let us know at info@hsa.org.uk or using the contact details provided at the HSA website.

The Vehicle

Every livestock vehicle must comply with basic construction requirements.

Every trailer or vehicle must:

- be constructed and maintained in a way which ensures the safety of the animals during loading, transport and unloading;
- protect animals from injury, unnecessary suffering, inclement weather and excessive noise and vibration;
- be free from sharp edges, protrusions, gaps and spaces which are likely to cause injury.

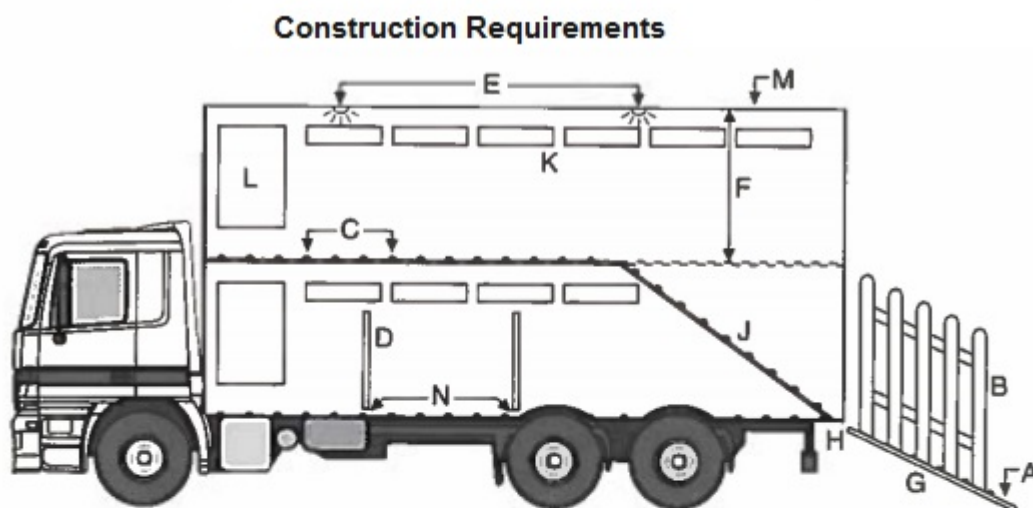

- | | |
|---|--|
| A Loading ramp with foot battens | G Slope of loading ramp no steeper than 29° |
| B Sidegates, minimum height 1.3m | H Step at top of ramp no more than 21cm, gap no bigger than 6cm |
| C Foot battens and/or non-slip flooring on all floors | J Slope of internal ramp no steeper than 33° |
| D Internal partitions minimum height 1.27m for cattle, 76cm for pigs, sheep and calves | K Adequate ventilation on all floors |
| E Adequate lighting for stock inspection | M Roof |
| F Height between floors must allow animals to stand naturally and provide adequate ventilation | N No large gaps between internal partitions and floors |

Drivers: Checks on vehicle construction and maintenance are **your** responsibility. Check every time you clean and disinfect. Report or fix any problems.

Stress in Animals

Stress occurs when animals have to make extreme and/or prolonged physiological and behavioural adjustments in order to cope with their environment.

S Situations
T That
R Release
E Emergency
S Signals for
S Survival

Animals can experience three types of stress:

- Physical – due to fatigue or injury.
- Physiological – due to hunger, thirst or temperature control.
- Behavioural – due to the environment, unfamiliar people or surroundings.

The factors which can cause stress are called stressors, e.g. noise, unfamiliar pen-mates or dogs. Although many animals might be able to tolerate a single stressor for a short period of time, multiple stressors over a long period of time may lead to distress and suffering.



The ability of animals to cope with stress will also depend on:

- the genetic background of the species;

- the animal's past experiences.
- Some degree of stress is inevitable during transport, the aim must be to keep it to a minimum.

Vibration, Noise and Movement

Vibration

The vehicle, with its engine running, will vibrate in small, rapid, regular movements. The animals will get accustomed to it over time and these vibrations should not cause a problem.

Noise

Animals will get used to the noise of the running engine. However, sudden noises can startle animals and cause agitation. Where possible, avoid overhanging trees and hedges that may hit the vehicle or trailer.

Movement

Vehicle movement will affect the ability of the animals to maintain balance. In extreme situations the animals may fall.

There are three basic types of movement which animals experience on a vehicle.

Up and Down

Excessive up and down movement can be limited by:

- maintaining correct tyre pressures;
- maintaining the vehicle's suspension system.

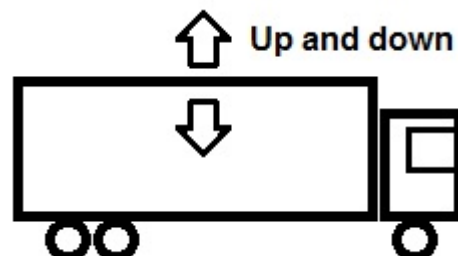

Side to Side

Limit side to side movement by:

- correct maintenance of the vehicle;
- driving according to the quality of the road;
- taking corners with care;
- avoiding stopping or overtaking.

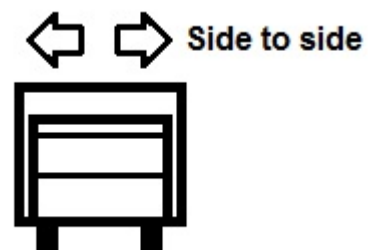

Forwards and Backwards

Forwards and backwards movement is limited by:

- accelerating slowly and smoothly;
- anticipating hazards;
- avoiding sudden braking;
- smooth changes of gear.

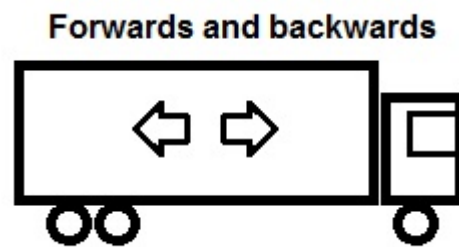

Ensure the vehicle is well-maintained. Remember you are carrying a living load.

Temperature and humidity

Mammals and birds are *homeotherms* which means they need to maintain a constant core body temperature.

If core body temperature falls the animals become *hypothermic*. A fall of 7-8°C is undesirable but can often be followed by complete recovery.

If core body temperature rises the animals become *hyperthermic*. An increase of only 5°C, in many cases, will be fatal.

Normal Body Temperatures in Livestock

Species	Body temperature	
	°C	°F
Cattle	38.7	101.7
Calves	38.6-39.3	101.5-102.7
Pigs	39.2	102-103
Sheep	39.4	103-104

Animals are constantly producing heat from their metabolism. They must balance this heat production with heat loss in order to maintain a constant body temperature.

Total heat produced by the animal = Total heat lost by the animal

Heat is lost to the environment by several routes: convection, radiation, conduction and evaporation.

Convection	Transfer by flow of air
Radiation	Transfer by emission of heat
Conduction	Transfer by contact with another surface
Evaporation	Transfer by evaporation of water, e.g. by panting or sweating

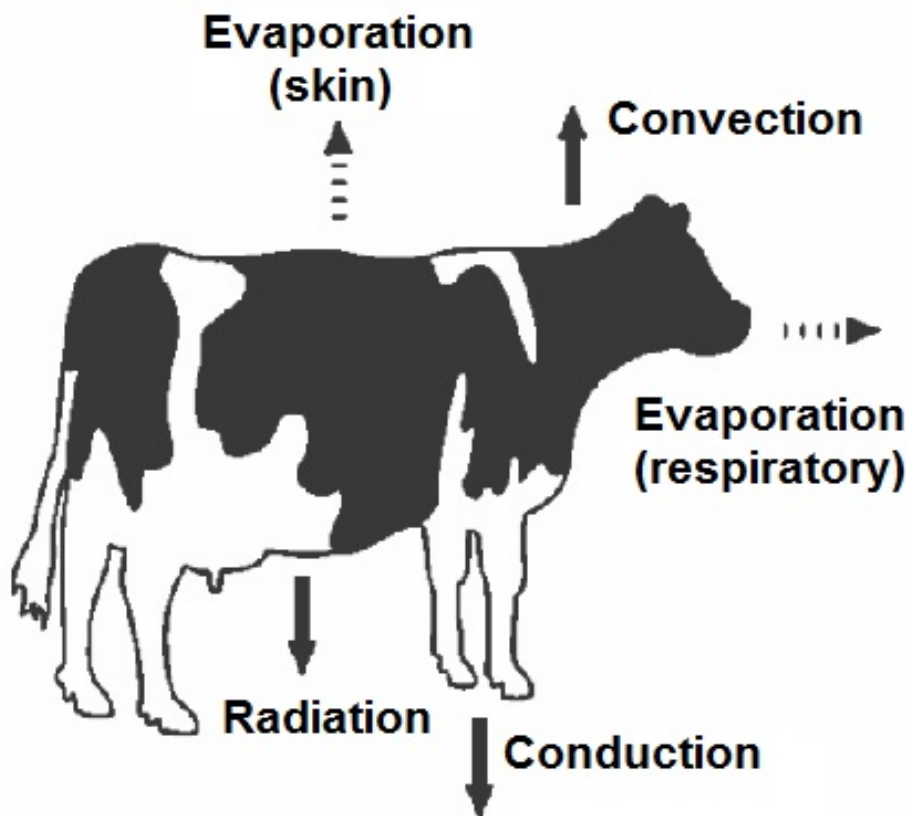

Loss of heat by convection, radiation and conduction is 'dry' and depends on there being a temperature gradient between an animal and its surroundings, eg when lying on a cold concrete floor there will be conduction of heat from the animal to the floor.

Loss of heat by evaporation is 'wet' and depends on there being a gradient of water vapour between an animal and its environment, eg when the atmosphere is hot and humid, the effectiveness of sweating or panting to cool down is reduced.

A combination of high temperature and high humidity can cause severe heat stress to animals within a livestock vehicle.

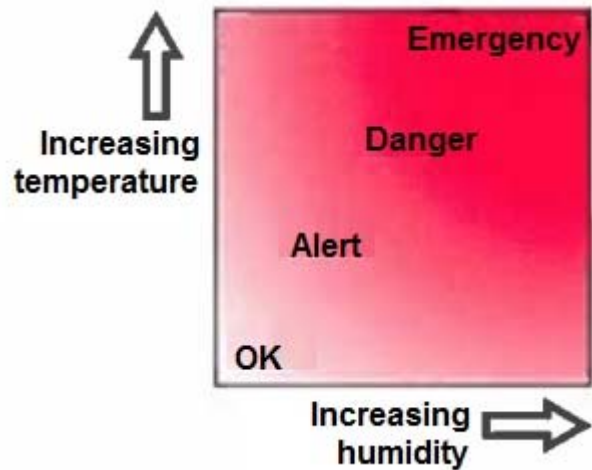

As animals are continually producing heat, the risk of heat stress is much greater than that of cold stress, particularly when the vehicle is fully loaded.

Typical heat output from animals

Theoretical values in **Watts**

Small calves (55kg)	120
Heavy cattle (550kg)	600
Shorn sheep (60kg)	117
Unshorn sheep (60kg)	117
Pigs (100kg)	161

Heat output from laden vehicle

Theoretical values in **Kilowatts**

Small calves (102 @ 55kg) 12.3

Heavy cattle (23 @ 550kg) 12.8

Shorn sheep (102 @ 60kg) 11.9

Unshorn sheep (76 @ 60kg) 8.9

Pigs (71 @ 100kg) 11.4

Animals conserve body heat or increase their body temperature by:

- shivering;
- piloerection (raising of the hair/coat);
- huddling;
- postural changes.

Animals are less likely to suffer cold stress in transit. The risk of cold stress is increased with cold environmental conditions, very young or shorn animals, or by having very few animals on the vehicle.

Vehicle Ventilation

The vast majority of livestock vehicles rely on natural ventilation to dissipate heat and moisture from animals.

Air flow

Air flow in a moving vehicle is from back to front.

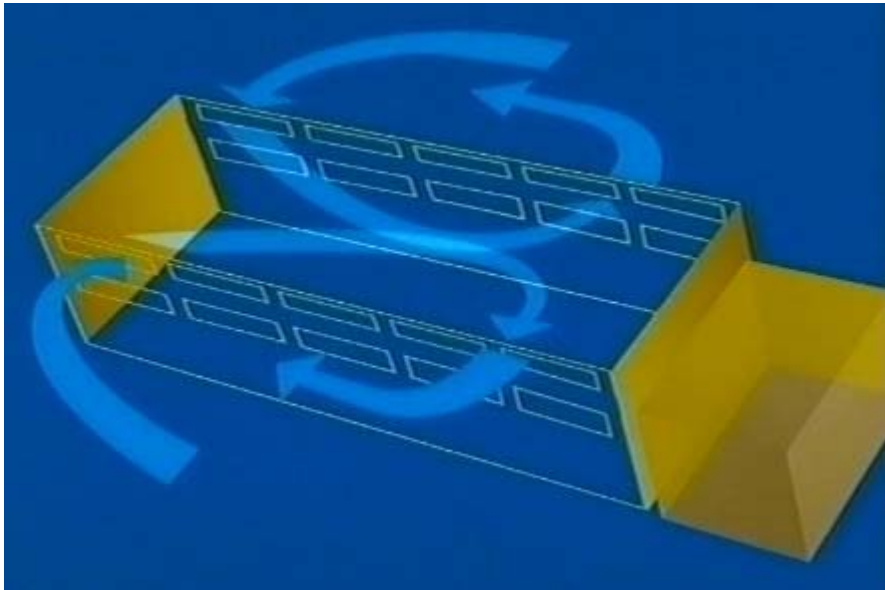

Hot spot

The hot spot is immediately behind the cab on the lower deck.

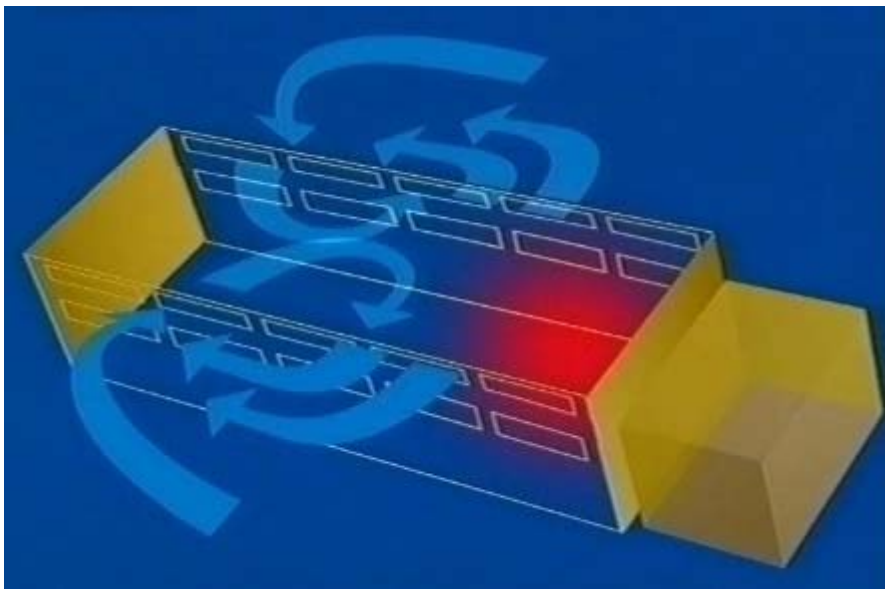

Cross winds

Cross winds can assist ventilation in a stationary vehicle on a windy day.

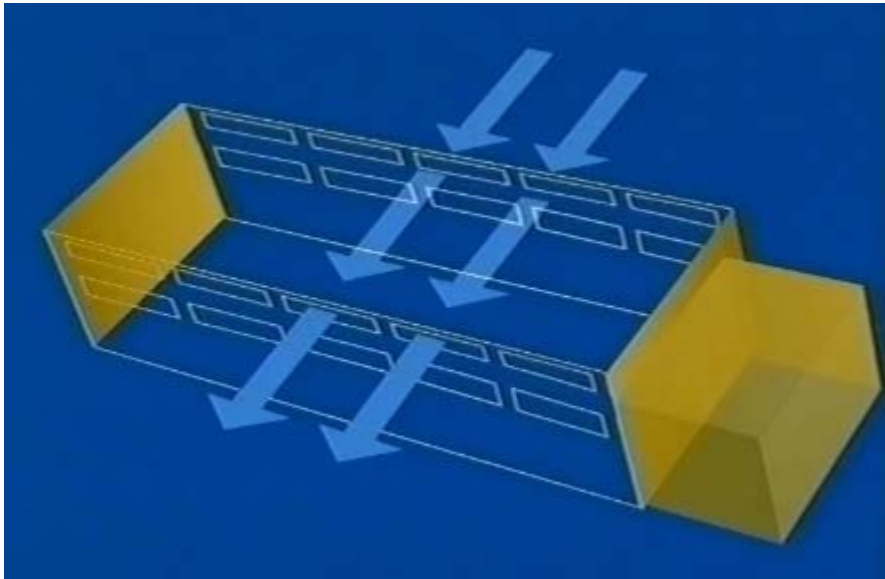

Closed flaps

When the vehicle is in motion on warm and humid days, provided the ventilation openings are large, close all but the rear and front flaps on both sides. This will increase the ventilation rate. Remember to open all the flaps again when stationary to permit cross winds.

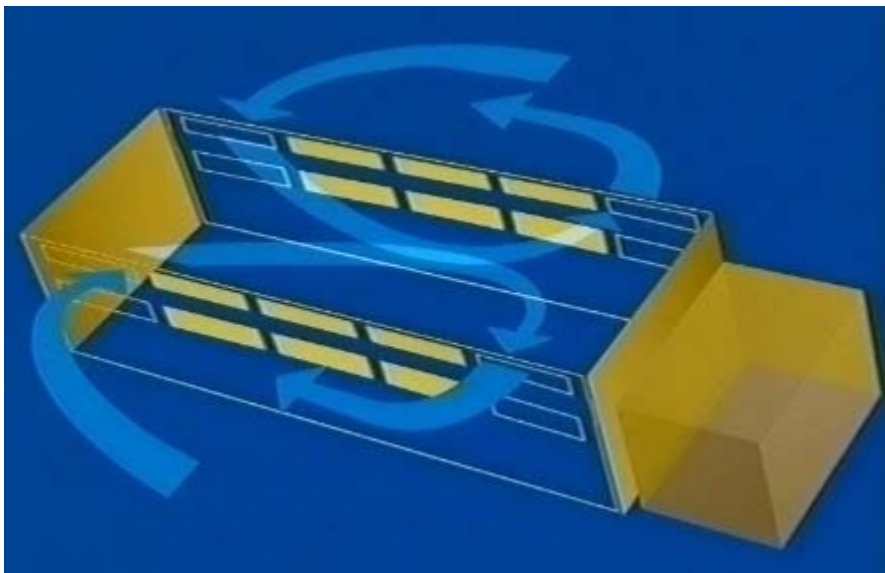

To limit heat stress:

- Optimise ventilation.
- Reduce stocking density.
- Travel in the coolest time of the day.
- Keep the vehicle moving.

If weather conditions suggest there is a risk of heat or cold stress, it is essential to inspect the animals regularly during the journey and to recognise the signs of thermal stress.

Signs of heat stress:

Panting and/or sweating

Postural changes (to increase heat loss)

Agitation and restlessness

Salivation

Exhaustion

Collapse

Signs of cold stress:

Shivering

Piloerection (raising hair/coat)

Huddling

Postural changes (to conserve heat)

Lethargy or drowsiness

Collapse

Summary

Reduce the risk of heat or cold stress by optimising the ventilation.

Inspect the animals regularly and recognise the signs of thermal stress.

Where possible, use rectal temperature to determine if thermal stress is present.

The biggest risk to livestock is a combination of high temperature and high humidity.

Space and Separation

Space

Careful penning of livestock within a vehicle is vital. Animals packed too tightly will be crushed or suffocated. If they are held too loosely, any sudden movement may cause them to fall and be injured.

Space allowances will need to be adjusted according to: weather, road and driving conditions; the journey length; the type and design of the vehicle; and the size, weight and category of the animal. The following is a guide.

Species	Category	Weight (kg)	Area per animal (m²)
Cattle	Small calves	55	0.30-0.40
	Medium calves	110	0.40-0.70
	Heavy calves	200	0.70-0.95
	Medium cattle	325	0.95-1.30
	Heavy cattle	550	1.30-1.60
	Very heavy cattle	>700	>1.60
Sheep	Shorn	<55	0.2-0.3
		>55	>0.3
	Unshorn	<55	0.3-0.4
		>55	>0.4
	Pregnant ewes	<55	0.4-0.5
		>55	>0.5
Pigs*	Pork	40-65	0.2-0.3
	Cutter	65-80	0.3-0.35
	Bacon	80-100	0.35-0.45
	Heavy	>100	>0.45

**Stocking density for pigs of around 100kg should not exceed 235kg/m²*

Increase space allowances by up to 20% in hot weather, over long journeys, when the route will be through a built up area, or if expecting slow moving traffic.

Larger vehicles will need to be subdivided into pens with suitable partitions. When vehicle pens are not at full capacity, partitions must be placed to ensure that animals are not thrown about by the motion of the vehicle. However, animals must not be packed so tightly so as to cause unnecessary suffering.

The following are recommended pen lengths:

Sheep, goats and pigs

The length of a pen must not exceed 3.1m

Cattle (not calves)

The length of a pen must not exceed 3.7m

Calves (i.e. cattle)

The length of a pen must not exceed 2.5m

Separation

When planning to transport any livestock, the penning arrangements will be affected by the need to separate certain groups of animals.

Do not mix species – unless separation would cause distress.

If possible, do not mix social groups (especially with pigs and cattle).

Do not pen animals of significantly different sizes together.

Separate vulnerable animals, such as those with young at foot.

Adult males must be kept separate unless reared together.

Tied and untied animals should not be penned together, with the exception of a mother with its young.

Horned and unhorned animals cannot be penned together unless they are secured by the head or neck.

Stocking density should take account of the size and species of animals, and the journey. Remember the rules of penning and separation.

Water, Food and Rest

Water, feed and rest are essential to all living animals, but these needs vary considerably. Livestock drivers must apply basic stockmanship skills to ensure that animals are watered, fed and rested appropriately. Maximum permitted journey times are often set down by law.

Water

Water requirements **decrease** with:

- moist food (eg lush grass);
- colder weather;
- non-lactating animals.

Water requirements **increase** with:

- dry feed (eg hay/concentrates);
- hot weather.

All animals should have access to fresh, clean water up to the point of loading.

When loading from markets or collecting points, be aware that the animals may not have had water for some time. Offer water before you start loading. The following is a guide to animals' normal requirements:

Species	Water requirements (litres/day)
Adult pigs	25
Adult sheep	20
Adult cattle	40
Milking cows	100-180

Animals not drinking normally may be ill or severely distressed.

On short journeys it is not a requirement to give animals water en route – indeed, if offered they would be unlikely to take it. As journey length increases, so the animals' needs will increase and they should be watered at appropriate breaks.

Signs of dehydration are:

- Pale gums
- Reduced skin elasticity
- Licking surfaces

If in doubt, offer water. Pigs are more prone to dehydration than ruminants. On arrival at your final destination offer fresh, clean water.

Food

Feeding requirements for livestock will depend on the species and journey length.

Pigs are monogastrics, the stomach is quickly filled and emptied and it is better to feed them regularly. Cattle and sheep are ruminants, with a complex digestive system which releases energy over a long period of time. They are more able to cope with longer periods of time without food.

Pigs:

Withdraw food before transport

Limit transport times

Sheep/Cattle:

Transporting off pasture can produce dirty animals

Take off grass before loading and feed small quantities of hay or straw

Cattle and sheep will usually eat in preference to drinking. Feeding mid-journey, where a stop is for less than eight hours, may result in dehydration.

Rest

All animals must be 'rested' for 24 hours before a journey begins. The maximum times that animals can be transported are often specified by law.

On long journeys, if given sufficient room, pigs, sheep and calves will lie down in the moving vehicle.

Adult cattle prefer to stand. After 10-14 hours they will show signs of fatigue and should be rested for a minimum of eight hours before being transported again.

Short stops on vehicles will give animals respite from the motion of the vehicle. However, this does not give them a real opportunity to 'rest'.

Key points: Water, feed and rest are essential to an animal's wellbeing. Requirements will vary depending on the species, previous feed and water patterns, and the intended journey.

Animal Behaviour

Livestock drivers need to understand the basics of animal behaviour. Not only will it help when handling animals, but it will be of use in identifying animals that are abnormal because they are ill, distressed, hungry or thirsty.

Animal behaviour is influenced in three basic ways:

- Innate
 - Basic instincts are programmed, eg the need to eat and drink.
- Sensed
 - The animals respond to stimulus from the environment, eg noise. Once a change or stimulus is detected by an animal, it will assess the situation and react accordingly.

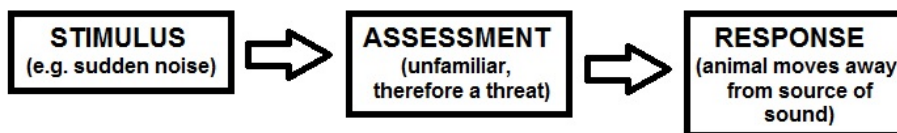

- Learnt
 - Animals may produce a response based on previous experiences, e.g. cows wait by the gate to come in for milking.

Behavioural characteristics

Animals perceive the world in a different way to humans and, likewise, the perception of a pig or a horse is not necessarily the same as that of a cow or a sheep. Different species have different behavioural characteristics.

Sheep

- are social 'follower' type animals;
- are a prey species and therefore have senses developed to be alert to danger;

- have a wide field of vision (340°) and can see moving objects at very long distances, but not those that are still;
- have acute hearing and will be startled by sudden noise;
- are generally docile but can be nervous and flighty;
- show strong flocking and following behaviour – isolation will usually cause distress;
- are relatively easy to handle, but mature rams may become aggressive.

Cattle

- have a strong herd instinct and develop a social order within the group. They dislike being isolated and mixing of different social groups will cause fighting;
- are large, strong and move quickly, despite their size and bulk. Direct contests of strength should be avoided, and they must be treated with respect;
- have a wide field of vision (340°) but only see well within narrow limits to the front;
- are poor judges of detail and distance – they dislike dark, shadowy areas and will shy at the slightest provocation;
- have a good sense of smell;
- hear sounds at similar and higher frequencies than humans – they dislike sudden, loud noises;
- can negotiate a gradual incline better than a steep slope and are not sure-footed moving downhill;
- bulls can become aggressive and it is unwise to work alone with these animals.

Pigs

- naturally come from a woodland environment and their senses have evolved accordingly;
- have a wide field of vision (310°) but this may be physically restricted in certain breeds (e.g. lop ear types);
- do not see well at a distance;
- have a good sense of smell and like to root about and investigate new surroundings;
- have good hearing;
- are very vocal animals and communicate using a complex vocabulary of grunts and squeals;
- do not have as strong a following instinct as cattle and sheep. They can be difficult to move and prefer not to be hurried – it is easier to guide pigs and let them find their own way;

- if rushed, they have a strong fear reaction and will pile on top of one another to get away;
- can be susceptible to stress and must be handled with great care.

Key point: Whether you handle cattle, sheep or pigs, learn to look at things from their point of view, to make your job quicker, easier and safer.

Animal Handling

Animals' activity levels can range from sleep at one extreme, through standing, grazing and playing, to fight or flight at the other. Handling will always raise the activity levels and the skill of a good livestock driver is to get animals active enough to move onto a vehicle but not so active that they become unmanageable and dangerous to handle.

Rough, aggressive handling produces animals which are:

- excitable and over-active;
- unapproachable and difficult to handle;
- more likely to cause injury to handlers.

The flight zone

All animals have an imaginary area around them called the *flight zone*. When a handler enters this zone, the animal will want to move away. The size of the flight zone will depend on the breed of the animal and its previous experience. Hill cattle and sheep will tend to have much larger flight zones than dairy animals which are accustomed to being handled regularly. A noisy and aggressive handler will also increase the flight zone.

To control an animal's movement, first position yourself on the boundary of the animal's flight zone, behind and to one side of the animal. Step just within the flight zone boundary (position A) to make the animal move forward. Move outside the flight zone boundary (position B) to stop forward movement. When you position yourself at the point of balance the animal should stand still. The same principles apply to moving groups of animals.

If you penetrate the flight zone too deeply the animal will attempt to get away, either by running from you if it can escape, or by turning back and running past (or at) you if confined. If an animal attempts to turn back, move away and once you are out of the flight zone the animal should stop.

The flight zone

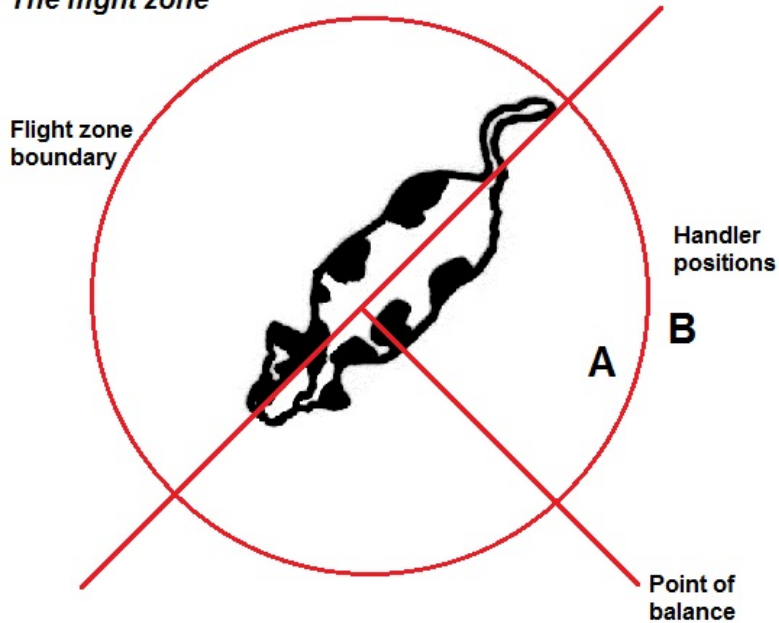

In order to reduce stress in animals, and make your job quicker, easier and safer, take note of the following guidance:

- Position
 - Take the correct position in relation to the animal – good animal handlers are always in the right place at the right time.
- Calmness
 - Be calm and quiet – noise and panic make animals more active, more excitable and more difficult to handle.
- Confidence
 - Be confident and be positive – animals sense fear and hesitation and will use it to their own advantage.
- Patience
 - Be patient and take your time – animals do not like to be hurried.
- Vigilance
 - Stay alert – you may have to move quickly; and be ready to anticipate and animal's behaviour.
 - Understand flight zones, be in the right place at the right time, and remain calm and quiet.

See Also: Humane Handling of Livestock Online Guide

Fitness to travel

Animals must be fit for their intended journey. Always give the animals the benefit of the doubt.

Signs of health

Head up, clean eyes, moist nose and alert.

Normal movement, no signs of discomfort or lameness.

Normal breathing, no coughs or wheezing.

No groans, grinding of teeth or arching of back.

Dry, clean coat with sheen, and pink healthy skin.

No signs of heat or cold stress.

Eating and drinking normally.

Urine pale and straw coloured.

Solid faeces, no diarrhoea or signs of constipation.

Normal pulse rates

Cattle

60 beats per minute
(under base of tail)

Sheep

75-80 beats per minute
(inside hind leg)

Pigs

70-80 beats per minute
(inside hind knee or over heart)

Also check livestock for fitness during the journey, eg when you stop for fuel or food. When you check the load, look for anything different. Ask yourself:

- How different is it?
- Is it relevant to the animals' welfare?
- When an animal becomes unfit during the journey, think about what you need to do:
- Should the animal be separated from others?
- Do you need to give the animal first aid?

- Do you need veterinary help?
- Can you complete your journey?

Casualty animals

The key issue when deciding if a casualty animal can be sent to the slaughterhouse or treatment centre is whether the animal can be transported without being subject to avoidable pain or distress. A number of points must be considered:

- Can the animal be loaded without using force and without causing additional suffering?
- Can the animal comfortably bear weight on all four legs and, if it is likely to stand during the journey, can it do so without pain or distress?
- What is the duration of the journey?
- What is the nature of the road over which the animal will be transported?
- Is the animal's condition going to deteriorate significantly over the time it takes to reach the slaughterhouse or treatment centre?
- Is there a slaughterhouse or treatment centre near enough which will accept the animal? It must be sent to the nearest available place of slaughter or treatment.
- Can the animal be looked after satisfactorily during the journey?
- Can suitable padding or bedding be provided?

If any of these questions, or other considerations, raise doubts about whether animals can be transported without avoidable suffering, they should be treated or slaughtered on the farm.

Key points: Know the signs of health and disease. Remember animals must be fit for the intended journey. Always give the animals the benefit of the doubt.

Loading and Unloading

Facilities

Loading livestock onto a vehicle is one of the most difficult handling procedures. Few farm animals undergo loading often enough to learn from experience, therefore handlers are usually dealing with untrained and nervous animals. It will help to have well-designed and properly constructed facilities. Ideally, loading and handling facilities should be designed at the same time. The species, maximum number of animals to be handled, and number of skilled handling personnel available, are factors to be considered when designing facilities.

Collecting pens

Floors of pens, raceways and loading areas should, as far as possible, be non-slip. Good footing for animals is essential.

Collecting areas and crowd pens should have solid walls. The only obvious way forward should be towards the lorry.

Metal gates should be padded to prevent clanging, be well-maintained and easily operated.

Raceways

Raceways and passageways to the loading area should be built with smooth, solid sides. Sharp corners or abrupt bends should be avoided.

Try to eliminate, as far as possible, shadow patterns, drain covers, large puddles and other apparent obstacles from handling areas. These may make animals baulk and reluctant to move forwards.

Most animals move readily from dark towards light, but dislike glaring sunlight or harsh artificial light. Take into account natural and artificial light patterns when designing handling facilities.

Loading bays

Raised loading bays reduce stress on animals and make loading easier.

There should be a gradual incline to the loading bay.

There should be a level area before animals move onto the tailgate of the vehicle.

Unloading areas

Unloading areas should be secure and provide a wide, clear straight path from the lorry to the yard, lairage or field. Animals should only have one obvious, clear direction in which to move.

Maintenance

All handling areas should be regularly checked for potential hazards, eg split rails, broken latches, dropped gates, and discarded objects.

Loading

Loading livestock can be a stressful process. Animals can be excitable and the risk of injury to them and handlers can be high. Take care.

Before you start

Plan ahead and allow plenty of time.

Ensure you know full details of the load, eg number of animals, species and type.

Make sure there are experienced helpers available.

Arrange and check all facilities thoroughly. Does everybody know what to do? Are all gates in the correct place? Is everything secure? Floors should be covered with some sand if the surface is slippery.

Remember, animals may be reluctant to move from their familiar housing pens into passageways. Eliminate anything that may cause animals to balk or shy.

Check all animals are fit to travel.

Check that partitions in the lorry are correct for the load – there may be some last minute changes.

Placing straw on the ramp may be helpful for certain age groups and species.

Light the interior of the lorry if necessary. Close ventilation flaps if sunlight is causing light and dark patches in the lorry which may make animals balk.

When loading begins

It will usually be easier to load several small groups of animals, rather than one large group.

Unless they are behind the animals, keep people out of raceways.

Avoid noise, rush and panic. Let animals find their own way, in their own time.

Make use of the animals' natural behaviour.

Encourage a lead-animal, giving it plenty of time to see where it is expected to go. Once it is on the ramp, encourage the group to follow.

Don't get too close to the animals which are moving forwards into the lorry – this may cause them to turn back. If they do, back off, let them down the ramp and give them time to relax before trying again.

Use your voice, flags, sacks or pig-boards to encourage animals to move in the right direction.

Be careful not to trap animals' legs or tails when closing partitions, side-gates or ramps of the lorry.

Be firm, but do not lose your self-control. If animals are being difficult, let them settle before trying again.

Unloading

Everyone involved with unloading should know which animals have to go where, before the tailgate is dropped.

Keep the slope of the ramp to a minimum; make use of a natural slope or use an unloading bay whenever possible. Particular care needs to be taken when unloading multi-deck vehicles. At no stage should any animals, even sheep, feel compelled to jump from a ramp. If they do, it indicates that the gradient is too steep.

There should be a clear route from the lorry to the lairage, yard or field. Animals may be tired and unsteady after the journey; allow them time to move off the lorry at their own pace.

Sick and injured stock

Be on the lookout for any sick or injured stock; separate and treat if necessary. Animals unable to move should be slaughtered on the vehicle.

Post-transit care

Allow animals time to settle down after any journey. Make regular checks to ensure they are drinking and feeding normally.

Key points: loading and unloading can be the most stressful part of the transport procedure. Check the facilities before handling animals. Facilities should be secure with a clear route on and off the vehicle. When moving stock, be calm and take your time.

See Also: Loading and Unloading Ramps in the online guide to Humane Handling of Livestock.